

INSTALLATION AND INSTRUCTION MANUAL

WEY® SLUICE GATES TYPE 4

Version 29.12.2009

Original documentation in the sense of 2006/42/EG

1. GENERAL

- 1.1 - Safety
- 1.2 - Designated service
- 1.3 - Marking

2. TRANSPORTATION, STORAGE

- 2.1 - Transportation
- 2.2 - Storage

3. INSTALLATION

- 3.1 - Preparation before installation
- 3.2 - Mounting aids
- 3.3 - Sluice gate with fixing clamps
- 3.4 - Sluice gate with anchor bolts for embedding
- 3.5 - Actuating components

4. COMMISSIONING

- 4.1 - General measures
- 4.2 - Safety measures
- 4.3 - Function test
- 4.4 - Manually operated equipment
- 4.5 - Pneumatically operated equipment
- 4.6 - Hydraulically operated equipment
- 4.7 - Electrically operated equipment

5. MAINTENANCE

- 5.1 - Operating cycles
- 5.2 - Cleaning / Lubrication

6. TROUBLE SHOOTING

7. REMOVAL

8. DISPOSAL

9. FINAL REMARKS

Anhang: Einbauerklärung

1. GENERAL

1.1 Safety

Prior to any work or start-up and in order to ensure a proper functioning of our products, the instruction manual for installation and operation must be observed.

Alterations on the products need our written approval. For consequential damages due to neglect of this direction, any liability will be rejected.



This symbol marks safety and risk advice. Follow all such advice in order to prevent any damages to human life and objects.



This symbol refers to important information.

The installation must be carried out according to established procedures and only by qualified personnel.

Project related data of valves, e.g. dimensions, materials and service range are found in the respective documentation.

1.2 Designated service

The WEY® sluice gate is used in drain channels and basins at sewage treatment plants and retaining reservoirs.

The sluice gate is suitable to shut-off pressure containing systems for water and sewage. The technical application limits referred to in the relevant project data documentation and this maintenance manual must be observed.

Should the WEY® sluice gate be installed in a explosive environment, the valve as non-electrical equipment, as well electrical equipment must be conform to RL 94/9EG, ATEX.

1.3 Marking

Manufacturer
Type / Material
Year/Fabr. No.
Comm. / Pos.
Size
Pressure max.
Medium temp.
Ambient temp.
Air supply pressure ¹⁾

Example



¹⁾ if applicable

2. TRANSPORTATION, STORAGE

2.1 Transportation

The transportation of sluice gates shall take place in a careful way. Lifting devices shall not be hooked onto stems nor other actuating components. Sluice gates shall be placed on even surface only, never tilted onto an edge, to prevent distortion of the frame. The equipment shall be protected against exterior damage and atmospheric exposure.

Large equipment will be supplied with additional transportation supports. These supports shall not be removed before final mounting.

2.2 Storage

Until final installation the equipment shall be stored in a dry, vented area. All function relevant parts shall be suitably covered against humidity, dust or other contamination.

For longer storage periods or in case of unfavourable storage conditions which could affect later the proper functioning, all blank surfaces, e.g. stem, piston rod shall be suitably protected by long term preservatives against corrosion.

Factory applied preservatives shall be checked for possible transport damages and appropriately repaired, if necessary.

For mounted accessories such as electric actuators, limit switches, solenoids, etc., the respective storage instructions of the manufacturer shall be observed with priority.

3. INSTALLATION

3.1 Preparation before installation

Onsite construction work details, recesses, walls, etc. shall be checked for accuracy, flatness, finish, etc. before starting with mounting the equipment.

Dimensions of any recesses have to comply with manufacturer's drawings and shall be checked acc. Fig. 1 and Fig. 2.

The walls shall be checked with plumb and level for its perpendicular (fixation of frame, stem guides and actuating components) as well as its horizontal and vertical flatness.

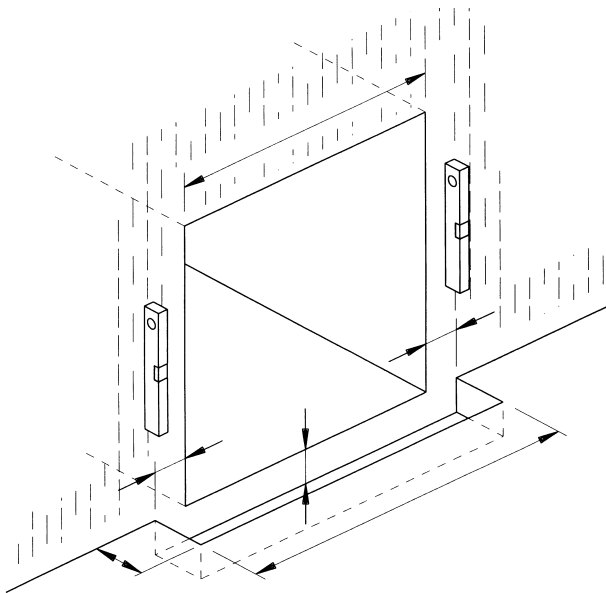

Fig. 1

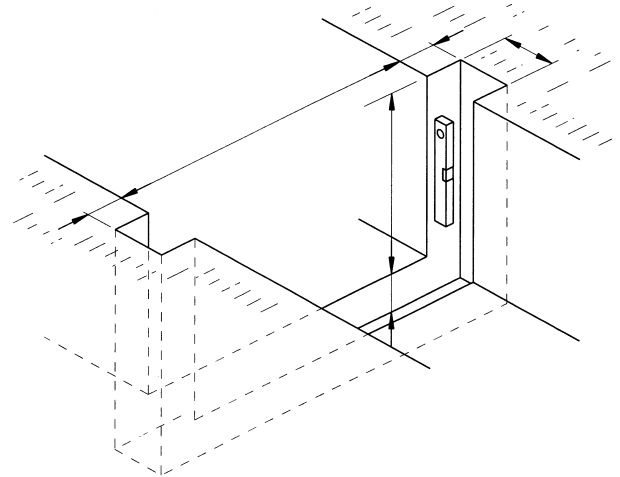

Fig. 2

Larger deviations must be corrected on site prior to mounting, as follows:

- a) by grinding, removal, equalizing of uneven surface;
- b) by applying concrete filler according to requirements (tightness, strength).

3.2 Mounting aids

In order to offset construction discrepancies, plastic or stainless steel shims or spacer plates in various thickness may be used to level and position the fixing frame, wall bracket and actuating components. Minor discrepancies can be compensated that way. The frame gets therewith enough wall support that it cannot be distorted when tightening the fixing bolts.

Major discrepancies must be compensated with threaded rods of suitable size if assigned bolts are too short (bad concrete quality, anchor hole too long or if many spacer plates had to be used). Cut to size threaded rods must be inserted and tightened with 2 nuts. After tightening the counter nuts must be removed and the threaded rod can be used in replacement of a short bolt.

To seal between frame and wall, paste type, medium resistant sealants are most suitable.



If filler or sealant is used, observe manufacturer's instructions with priority.

3.3 Sluice gate with fixing clamps



Mounting and embedding work shall take place with sluice gate in completely closed position only. For best sealing between wall and frame, the wall construction must be dry.

Procedure

- Position sluice gate in the respective recess or in front of the wall opening to shut-off and align with plumb and level, acc. Fig. 3.
- The clamps must be marked and fixing holes drilled according instructions. The two top clamps (for weir gates the two bottom clamps) serve also as travel stops.

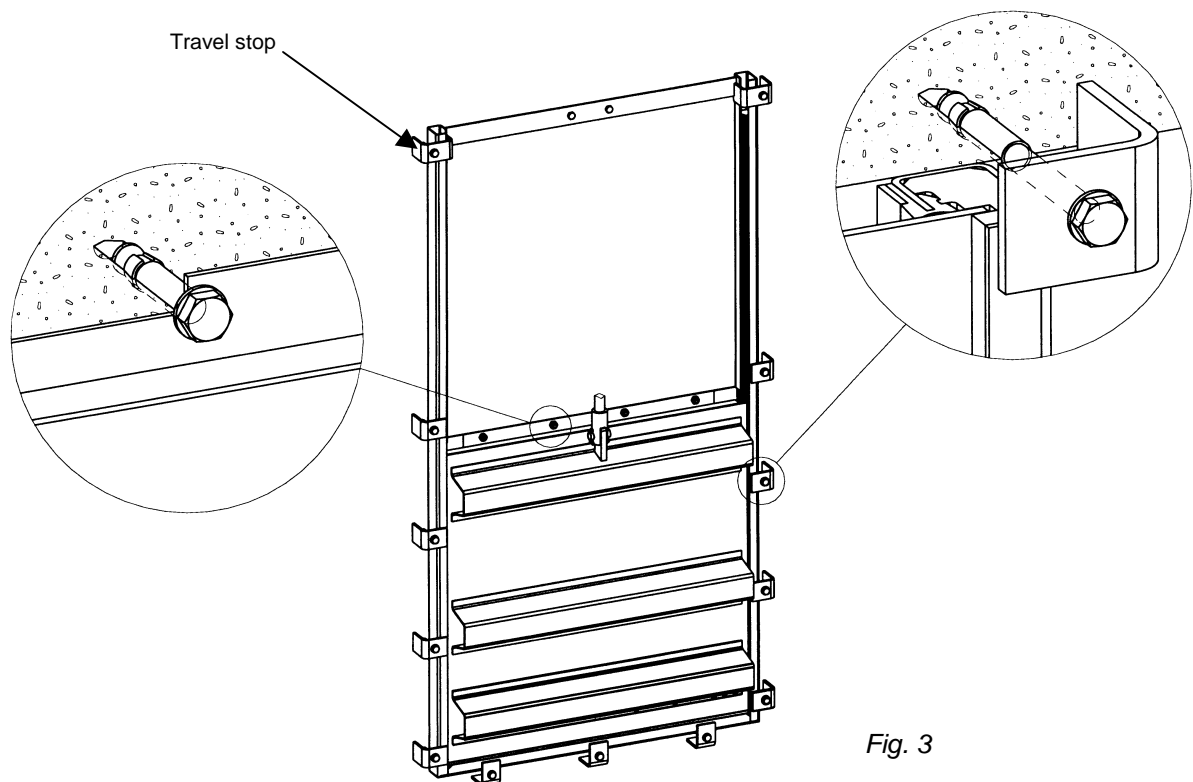

Fig. 3

- Depending on the size of the sluice gate, 1-2 dowels per side should be set to fix frame temporarily with bolts.
- Check alignment with plumb and level. Readjust position of sluice gate, if necessary.



Upper level of bottom profile must comply with **finished floor level** according to site plan.

- Drill and set remaining dowels for all clamps and also on the transverse seal, if applicable.
- Prior to final fixation, pull frame slightly away from the wall in order to place two rows of sealant (according supplier's instructions) behind the frame and transverse seal up to the max. height of water head, respectively to the transverse seal (Fig. 4 and 6). If bottom seal is bolted, sealant shall also be placed there.
- All bolts can then be firmly tightened with the **torque key**, according to the **product/supplier's specification**, starting at the transverse seal and afterwards the clamps.

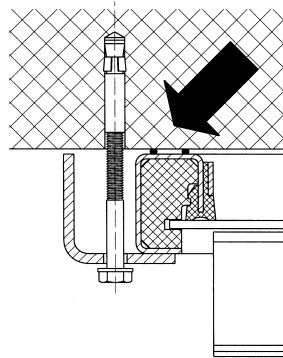

Fig. 4

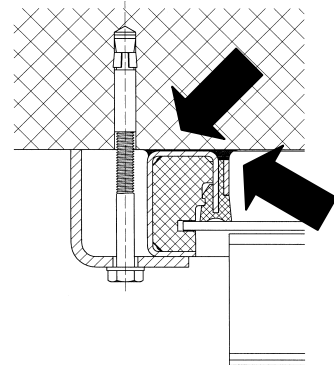

Fig. 5

- When tightening the bolts, the sealant gets squeezed out on both sides of the frame. Smoothen sealant with finger to a clean grout (Fig. 5).
- For sluice gates with transverse seal an additional grout is necessary after tightening between wall and transverse seal acc. Fig. 7.
- After mounting the actuating components (acc. 3.4) the sluice gate shall be opened and the sealant on the inside of the frame and transverse seal shall be smoothed to a clean grout acc. Fig. 5 and Fig. 7.
- The bottom profile, if existent, requires onsite embedding with filler or mortar acc. Fig. 8.



When filling these recesses **never use any vibrators !**

Bottom and transverse seal profile shall be free of any concrete or other contamination.

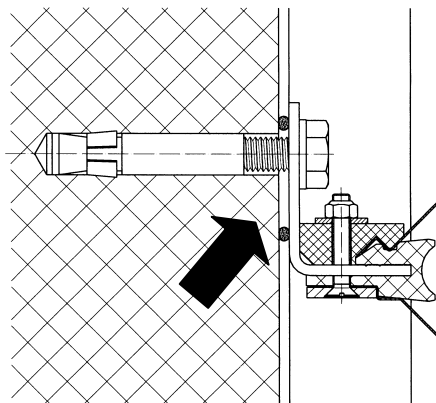

Fig. 6

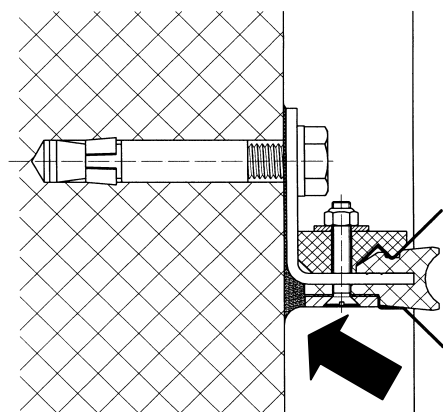

Fig. 7

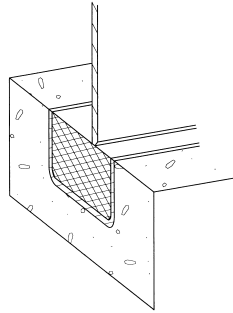

Fig. 8

3.4 Sluice gate with anchor bolts for embedding



Mounting and embedding work shall take place with gate in completely closed position only.

Procedure

- Position sluice gate in respective recess and align with plumb and level acc. Fig. 9.
- Depending on size and weight of sluice gate, 2-3 dowels per side should be set into the recess and bolts be inserted (Fig.10).
- If supplied with transverse seal, set bolts and seal thereafter, as described in 3.2.
- Align sluice gate with plumb and level and fix frame.
- If necessary, tighten bolts at the transverse seal.
- Connect anchor and dowel bolts in the recess with a bar profile by welding acc. Fig. 10.



Always position sluice gate with mounting aids of steel, never use wood wedges. Sluice gate must never be weld-connected to concrete reinforcement bars.

- Check alignment with plumb and level. Realign sluice gate, if necessary.

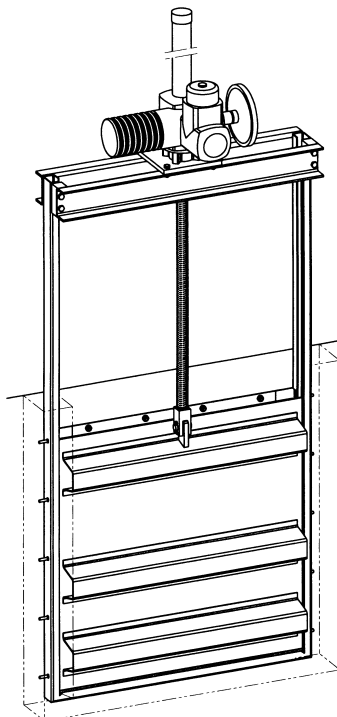

Fig. 9

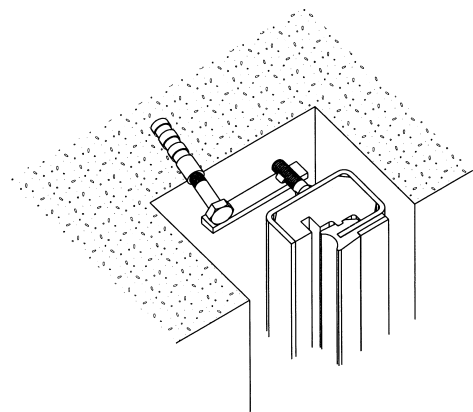

Fig. 10



Upper level of bottom profile to comply with **finished floor level** according to site plan.

- The positioned sluice gate is now ready for onsite embedding.



When filling these recesses **never use any vibrators !**
Bottom and guide profile shall be free of any concrete or other contamination.

3.5 Actuating components



Sluice gates with separately supplied actuating components, must not be actuated prior to embedding.

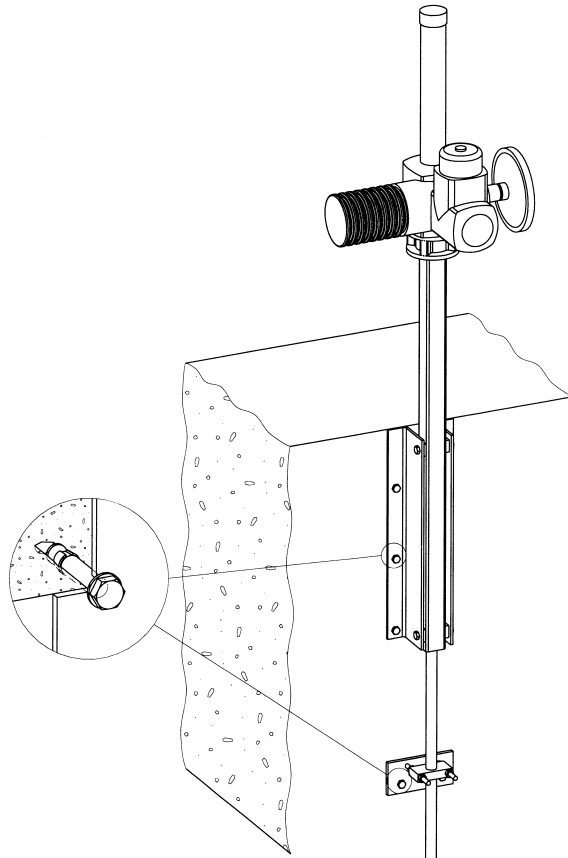

Fig. 11

Procedure:

- Extension rod with coupling to be pinned to the bare shaft of the stem. For coupling procedure keep wall bracket loose on the extension rod.
- Align coupled extension rod with plumb and level acc. Fig. 11.
- Position wall brackets and drill holes.
- Check alignment of all components with plumb and level. Realign if necessary, using suitable shims.
- For additional supports, floor stands etc., appropriate positioning and alignment is required before drilling holes.
- Set dowels and bolts.
- Check alignment of all components with plumb and level. Realign if necessary, using suitable shims.
- Mount and fix all actuating components.

3.5.1 Travel adjustment

For automated sluice gates the final end or travel position must be adjusted. In the closed position it must be ensured that the gate slightly compresses the bottom seal. (see also chapter 4.4./4.5 commissioning)

Pneumatic/Hydraulic Actuators:

In the closed position the piston must mechanically touch the cylinder bottom (Fig. 12 "A"). In order to reach the necessary bottom seal compression adjust stroke by fixing either piston rod or clevis with an approx. ½ turn setting outwards (longer), see (Fig. 12 "B").

Electric Actuators:

The limit switches must be set acc. manufacturer's instructions. Close sluice gate first with manual override until slight compression of the bottom seal is reached, then set the limit switch "closed". Thereafter open the sluice gate and set the limit switch "open" just before the mechanical travel stop is reached.

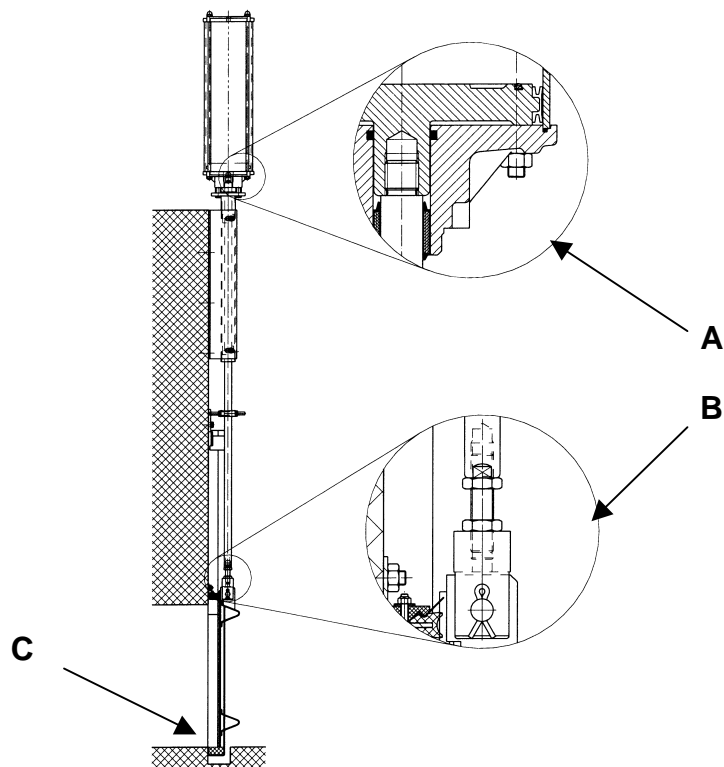

Fig. 12

4. COMMISSIONING

4.1 General measures

Before taking the equipment into service, all function relevant parts (stem, piston rod, gate, gate guides, seals) shall be thoroughly cleaned.

The equipment is factory preserved and lubricated for transportation and storage, but it may require further lubrication before start-up depending on the service conditions.

Lubrication shall take place according to supplier's schedule. Recommended are water-repellent, temperature resistant and long lasting lubricants. (Get recommendations from your supplier).

4.2 Safety measures

The moving parts (gate) of automatic must not have free access. If need be they must be sheathed or protected. Unprotected sluice gates are not allowed to be taken in operation. Especially Special attention is required for afterwards added protection, for example grid. Together with the gate these parts could generate crushing obstacles
The actuator operating equipment must at all times be safely accessible.



Air borne noise émission:

Electrical actuation	< 70 dB (A)
Pneumatical actuation (Solenoid valve inclusive silencer)	< 85 dB (A)



It is prohibited to stay in the sluice gate flow area whilst the system is under pressure and the actuation equipments are connected to the main



Ensure that no external interference of the electric control circuits can actuate the valve unintentionally.

4.3 Function test

Before commissioning a function test must be performed. Therefore open and close the sluice gate at least once.

For embedded sluice gates a function test shall not take place before grout compound is dry and capable of bearing the structure.

If a pressure test is performed, ensure that the applied pressure does not exceed the maximum allowed test pressure of the sluice gate.

4.4 Manually operated equipment

Check sluice gate for ease of operation (reasonable forces).

Also check the setting of the limit switches (if applicable)

4.5 Pneumatically operated equipment



Ensure with suitable measures that the maximum working pressure does not exceed (8 bar), also not in a breakdown situation

To operate the actuator, use
dry, filtered air acc.

	Class 4/5 ISO 8573-1
max. dust particle size	40 µm
max. dust particle concentration	10 mg/m ³
max. excess oil concentration	5 mg/m ³
pressure dew-point	below minimal ambient temperature

Solenoid valves shall be mounted as close as possible to the actuating cylinder.



Air hoses, especially plastic pipes must be mounted and secured so that they cannot be unintentionally interrupted or pulled-off. In order to keep a valve tight in its closed position, the piston must be permanently under pressure.

The size of the air supply pipes has to be in relation to the required air volume.

Before start-up, all on-site mounted supply pipes and solenoid valves shall be thoroughly flushed and cleaned, if necessary.

Factory mounted solenoid valves are normally supplied without accessories like throttles or mufflers. On-site directives must therefore be observed.

4.6 Hydraulically operated equipment

Before commissioning all on-site mounted supply pipes shall be thoroughly cleaned. Supplier's instructions must be observed.

4.7 Electrically operated equipment



For electrical installations observe local rules, standards and directives. In addition directives and guidelines for the installation and operation of explosion protection equipment must be observed, if the equipment is installed in a Ex-zone.

Check if the electrical equipment fulfils the safety requirements at site.

After installation a correct earth-connection must be verified. This is normally ensured through the flange bolt connection. If this is not the case, suitable measures must be taken.

For trouble-free commissioning of electric actuators, we recommend to call on our specially trained customer service specialist.

Electric on-site installations shall be in accordance with the provided connecting diagram. In addition, the specific operating instructions of the actuator supplier shall be observed.

Move the gate into an intermediate position with the manual override before starting operation electrically for the first time.

When connecting to the power supply, the phase sequence must to be observed.



With wrong phase sequence, limit and torque switches are ineffective.

The switch-off shall be in accordance to our instructions/diagrams, i.e.:

Switch-off in closing direction: usually by limit switches, exceptionally with torque switches possible.

Switch-off in opening direction: by limit switches only, as the torque switch serves as overload protection.

5. MAINTENANCE

5.1 Operating cycles

During one year, at least four (4) operating cycles shall be performed, whereby the functioning of all components shall be checked. Under severe service conditions, such functional checks shall take place more frequently.

5.2 Cleaning / Lubrication

Gate guides, stems, stem nuts and piston rods shall be free of dirt and contaminations and shall always be well lubricated.

Grease ports at the handwheel bearing shall be lubricated in regular intervals depending on the application and service conditions, but at least every three months.

Pneumatic cylinders with cushioned closing are supplied with a self-lubricating piston rod seal.

The elastomer seal in the gate guides shall also be lubricated to avoid sticking tendency of gate and seal after longer shut-down periods.

Water-repellent, temperature resistant and long lasting lubricants shall be used (Get recommendations from your supplier).

For equipment with electric actuators, the lubrication ports on the drive should be especially observed (version with rising stem).

The respective operating and maintenance instructions of the actuator supplier are binding.

6. TROUBLE SHOOTING

Symptom	Cause	Remedy
Leakage between gate and transverse seal	Transverse seal damaged Gate contaminated or calcified	Replace transverse seal according to manufacturer's instructions Clean gate
Leakage between frame and wall construction	Sealing grout defective Dowel bolts loose	Repair or remove and renew grout Tighten dowel bolts
Leakage through seat	Gate not completely closed; jammed particles between gate and frame members	Manually operated equipment: - Open gate slightly and repeat closing action - Remove jammed particles
	Jammed particles between stem nut and transverse seal member	Pneumatically and oil hydraulically operated equipment: - Open gate slightly and repeat action. - Check if new setting of clevis, resp. stroke is necessary. - Remove jammed particles
		Electrically operated equipment: - Open gate slightly and repeat closing action; check; possibly reset limit switches (acc. supplier's recommendation) - Remove jammed particles
	Seals damaged	Replace seals according manufacturer's instructions
Gate can not be moved	Actuating components damaged	Manually operated equipment: - Check and clean stem, stem nut, gate and guides; replace if necessary; lubricate
	Actuating components damaged	Pneumatically and oil hydraulically operated equipment: - Check supply pressure - Check if current on to solenoid existent - Check solenoid for damages - Check actuating cylinder for damages (seals) - Clean and lubricate, if necessary replace damaged components acc. to supplier's instructions.
		Electrically operated equipment: - Check if current existent. - Check if motor defect. - Check if limit switches defect or mal-set. - Check if gear, stem or stem nut damaged. - Clean and lubricate, if necessary replace damaged components acc. to supplier's instructions
Closing or opening stroke ceasing or stagnating	Insufficient supply pressure	Pneumatically and oil hydraulically operated equipment: Check supply pressure; possibly increase supply pressure
	Solenoid valve dirty	Remove and clean solenoid valve, possibly install filter
	Piston rod seal damaged	Remove and clean piston rod seal, replace cylinder seals and lubricate
	Gate guides clogged	Clean and lubricate
Pressure loss on supply net	Pipe connections damaged	Check pipe connections, tighten, replace if necessary.
	Cylinder seals damaged	- Check and replace cylinder seals, lubricate - Check piston rod, clean, lubricate

7. REMOVAL



Before removing the valve, consider that the pipe system can be under pressure and that hazardous media could get into the environment. Respective precaution measure must be taken.

Sluice gate frames will normally not be removed. They remain fixed to the wall construction for service life.



Actuators must not be removed if equipment is under pressure.
Before removing electric actuators cut power, respectively disconnected from circuit.
Pneumatic and hydraulic actuators must be de-pressurized and disconnected from supply lines.

8. DISPOSAL

Observe that sediments or contaminations as well as lubricants, cleansers etc. which may adhere to the equipment or pipe could be harmful to people and environment. Respective precaution measures are to be taken.

After finished service life, the valve must be disposed skilful and in conformity with environmental regulations.

9. FINAL REMARKS

All information presented are to the best of our knowledge and shall provide, in combination with our technical documentation, information about our products and their range of applications.

They are not thought to assure particular features of the products nor their suitability for a specific service.

Faultless quality is assured within our General Sales Conditions.

For any further information, call on our Customer Service Department at any time.

ALTERATIONS AND ADDITIONS RESERVED

Einbauerklärung / Declaration of Incorporation

nach Maschinenrichtlinie 2006/42/EG Anhang II B
Following the EC Machinery Directive 2006/42/EC Appendix IIB

Absperr-Armaturen der Typenreihe
Valves of the Series

Bezeichnung: **WEY® Schütz**
Description: **WEY® Sluice Gate**

Typ / Type: **3.3, 3.4, 3.5, 4.3, 4.4, 4.5**

Betätigungsart: **elektrisch, pneumatisch, hydraulisch**
Method of actuating: **electric, pneumatic, hydraulic**

sind zum Einbau in Rohrleitungen bestimmt.
are determined for the installation into basins and chanal systems.

Hiermit erklären wir, dass die Produkte den folgenden grundlegenden Anforderungen der EG Richtlinie 2006/42/EG entsprechen:
We herewith declare that products meet the basic requirements of the EC Directives 2006/42/EC:

Anhang I, Artikel / *Appendix I, Article*

1.1.2	1.1.3	1.1.5	1.3.2	1.3.4	1.5.1	1.5.3	1.5.4
1.5.6	1.5.7	1.5.8	1.5.9	1.5.11	1.5.13	1.7.3	1.7.4

Folgende einschlägigen Bestimmungen / Normen wurden angewandt:
Following appropriate standards / normative documents were applied:

EN 12100-1
EN 12100-2

Wir erklären, dass für diese unvollständige Maschine die speziellen technischen Unterlagen nach Anhang VII Teil B erstellt wurden und verpflichten uns, diese auf begründetes Verlangen den Aufsichtsbehörden in elektronischer Form zu übermitteln.
We declare that for this incomplete machinery the specific technical documentation according Appendix VII part B were prepared and commit ourselves to submit these by email upon qualified request to the Controlling Institution.

Die Inbetriebnahme ist solange untersagt bis sichergestellt ist, dass die gesamte Anlage, in welche die Produkte eingebaut sind, den Bestimmungen der EG-Richtlinie 2006/42/EG und allen relevanten Sicherheitsbestimmungen entspricht.
The commissioning must not take place until the complete machinery or plant, into which the valve is incorporated, has been declared in conformity with the provisions of the EC Machinery Directive 2006/42/EC.

Bevollmächtigter für die Zusammenstellung der technischen Unterlagen:
Authorized representative for the technical documentation:

Fredy Baumli, E-mail: f.baumli@sistag.ch, Tel: +41 (0) 41 449 99 30

SISTAG AG
Absperrtechnik

