

Instruction manual

6.30.10



Typ TK



Typ RSK

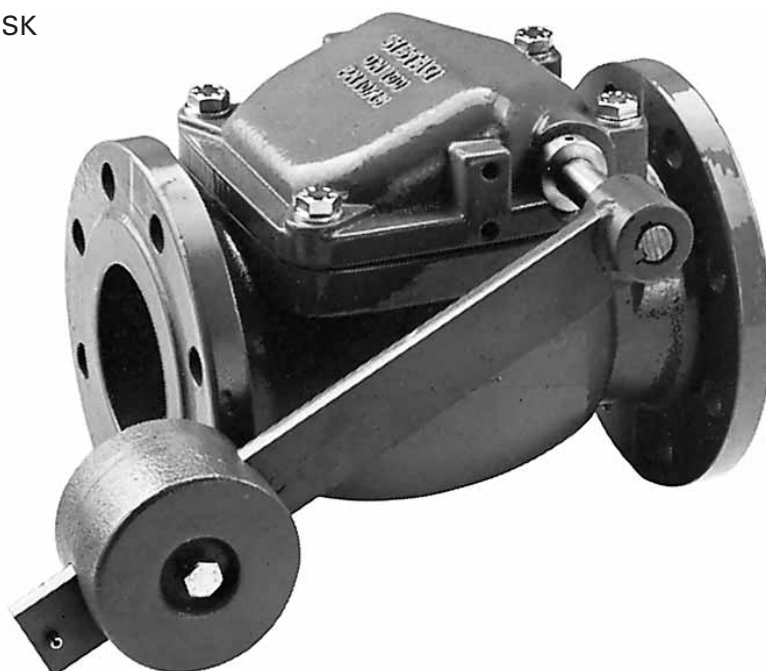

Check Valve Type TK/RSK

CHECK VALVE TYPE TK/RSK: INSTRUCTION MANUAL

- 1. GENERAL**
- 2. TRANSPORTATION, STORAGE**
 - 2.1 - Transportation
 - 2.2 - Storage
- 3. INSTALLATION**
 - 3.1 - Preparation before installation
 - 3.2 - Installation site
 - 3.3 - Installation position
 - 3.4 - Mounting
- 4. COMMISSIONING**
 - 4.1 - General measures
 - 4.2 - Safety measures
 - 4.3 - Type TK, RSK
 - 4.4 - Type TK - Reservoir version
- 5. MAINTENANCE**
 - 5.1 - Operating cycles
 - 5.2 - Checks / Lubrication
- 6. TROUBLE SHOOTING**
- 7. FINAL REMARKS**

1. GENERAL

Prior to any work or start-up and in order to ensure a proper functioning of our products, the instruction manual must be observed.

Alterations on the products need our written approval. For consequential damages due to neglect of this direction, we have to reject any liability.

2. TRANSPORTATION, STORAGE

2.1 Transportation

Transportation of the valves to their final destination (building site) shall take place in solid crates adapted to the valves' size. The valves shall be protected against exterior damage and atmospheric exposure.

Depending on the duration of transportation or storage and in view of the conditions, preservation shall take place by welding valves into PE-film or adding sufficient drying agent or equal.

2.2 Storage

Until final installation the valves shall be stored in a dry, shaded and vented area. All function relevant parts shall be suitably covered against humidity, dust or other contamination.

The valve disc shall be in open position for relief of the rubber seat.

Factory applied preservatives shall be checked for possible transport damages and appropriately repaired according supplier's instructions, if necessary.

For accessories mounted to the valves, such as electric actuators, limit switches, solenoids, etc., the respective storage instructions of the manufacturer shall be observed with priority.

3. INSTALLATION

3.1 Preparation before installation

Not correctly aligned pipelines must, by all means, be corrected before installation in order to avoid tensions or even cracking of the valve body.

Before final installation of the valves, all parts and in particular the bore passage and the disc seal shall be free of dust and dirt.

3.2 Installation site

The Installation site shall be chosen so that the valves are well accessible for functional checks or maintenance work.

For outdoor installations, the valves shall be protected at site with shields or covers against severe weather conditions like snow and ice.

3.3 Installation position

The check valves can be installed either horizontally or vertically.

Therefore the respective lever positions acc. Fig. 1, 2 and 3 are to be observed.

HORIZONTAL LINE

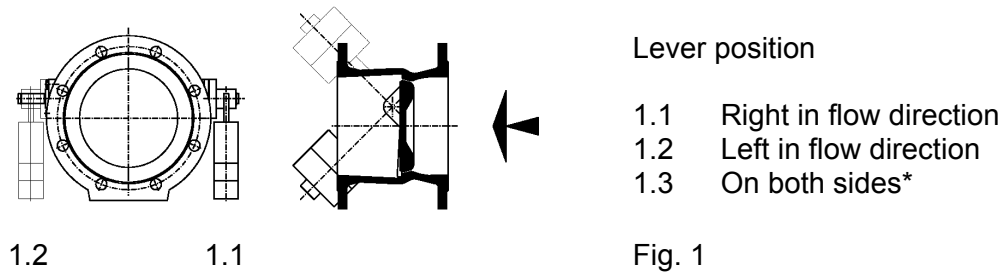

VERTICAL LINE

FLOW FROM BOTTOM TO TOP

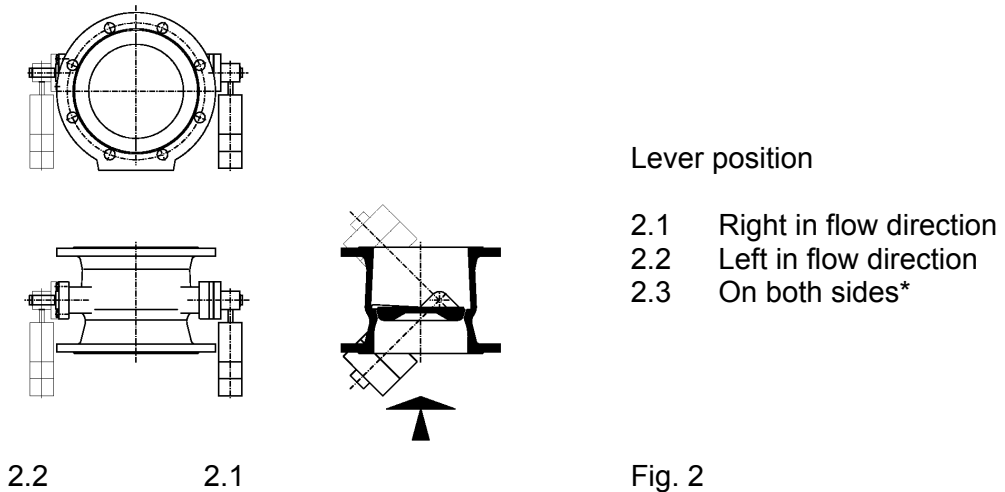

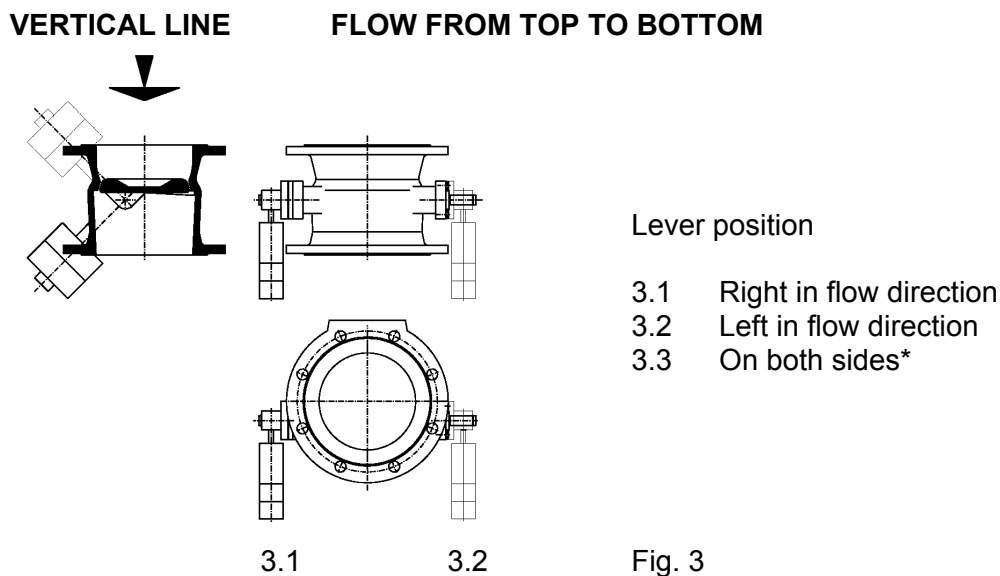

* If arrangement with two levers, no adjustable stop can be mounted.

3.4 Mounting

Before mounting, valves to be checked for possible transportation or storage damages.

The valves shall be protected against construction work at site.

If lifting devices are used, valve shall be hooked at the flange holes and not at the counter-weight lever.

The flange pattern consists of through holes. Apply flange bolts acc. Fig. 4.

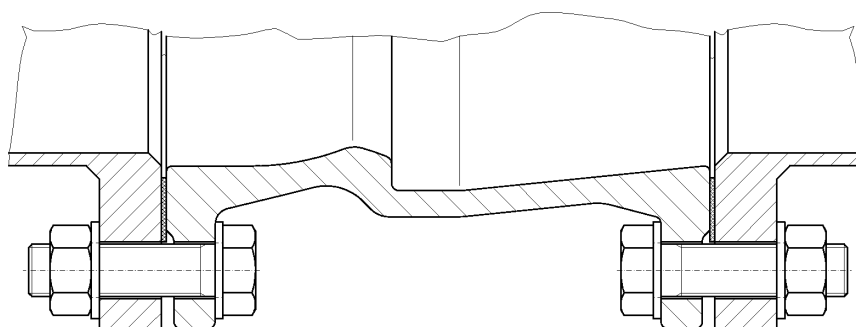

Fig. 4

The thread dimensions and the number of bolts are found in the dimension sheets.

ATTENTION: Tighten bolts cross-wise with caution, so that tensions in the body do not cause any cracking or breaking. No tilting, steady tightening.

4. COMMISSIONING

4.1 General measures

Before taking the valves into service, clean body and actuator thoroughly.

Check valve coatings for possible mounting damages and repair acc. to supplier's instructions, if necessary.

4.2 Safety measures

For automated valves installed in an area where valve movement could be dangerous for people (or animals/objects), it must be ensured by the user on-site that all moving parts are fenced with a suitable cover or protection shield.

Such covers are optionally available from manufacturer.

4.3 Type TK, RSK

Check ease of operation by lifting and let go of the lever with counterweight. Valve must shut pressureless.

The slidable counterweight has to be set for the respective pressure situations.

4.4 Type TK - Reservoir version

For little pressure differentials, the attachment of our adjustable stop is recommended.

This stop shall be set with the existing spring load in regard to the respective pressure situation in order that the valve disc will open from the seat in a pressureless stage.

5. MAINTENANCE

5.1 Operating cycles

During one service year, at least four (4) operating cycles shall take place, whereby all components shall be checked. Under severe service conditions, such functional checks shall take place more frequently.

5.2 Checks / Lubrication

Periodic maintenance or lubrication of the valve is under normal service conditions not necessary.

To avoid any damage due to longer stand-still periods, the valve disc has to be set into a slightly open (10°) position.

When recommissioning, follow the steps under commissioning (para 4).

6. TROUBLE SHOOTING

Trouble	Possible Cause	Elimination
Leakage in bore passage of valve	Valve disc not completely closed; jammed particles between disc and body internals	Type TK <ul style="list-style-type: none"> - Open valve slightly and repeat closing action. - Remove jammed particles. Type RSK <ul style="list-style-type: none"> - Remove valve cover, clean disc.
	Disc seal damaged	Type TK <ul style="list-style-type: none"> - Remove valve, replace seal. Type RSK <ul style="list-style-type: none"> - Remove valve cover, replace disc.
Valve disc heavily movable	Valve clogged, calcified	Type TK <ul style="list-style-type: none"> - Remove valve, clean, decalcify. Type RSK <ul style="list-style-type: none"> - Remove valve cover, clean, decalcify.
Leakage through shaft bearing	Seals damaged	Type TK <ul style="list-style-type: none"> - Remove valve, replace seals. Type RSK <ul style="list-style-type: none"> - Remove valve cover, replace seals.
Leakage between valve flange and pipe flange	Valve and pipe flange not parallel	- Correct pipe flange alignment.
	Flange bolts not tightened	- Tighten bolts firmly.

7. FINAL REMARKS

All details given above are to our current up-to-date knowledge and shall provide, together with our technical documentation, information about our products and their range of applications.

They are not thought to assure particular features of the products nor their suitability for a specific application.

Faultless quality is assured within our General Sales Conditions.

For any further information, please call any time on our Customer Service Department.

ALTERATIONS AND ADDITIONS RESERVED