

WEY® Knife Gate Valve Type MFC

2.2.30

DN 50–600

Standard Construction

Valve operated by pneumatic cylinder

Supply pressure: 6–8 bar

Material acc. to data sheet 2.0.13

Coating acc. to data sheet 2.0.12

Flange drilling: PN10/16
 EN1092/ISO 7005

Face-to-face: EN 558-1/ISO 5752 part 20

Nominal pressure PN:
 DN 50–300 10 bar
 DN 350–400 6 bar
 DN 450–600 4 bar

Operating pressure: Refer to table column OP

Test acc. EN-12266-1, rate A

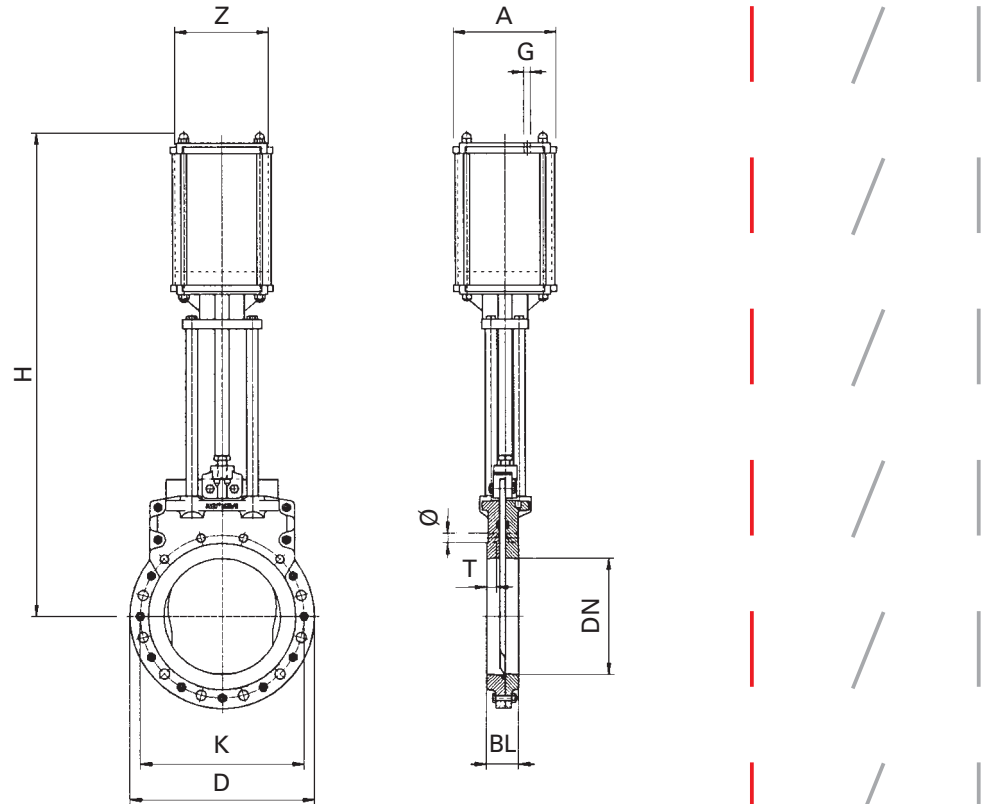

All information for reference only

Technical modifications reserved

DN	D	K	BL	H	Z	A	G	Ø	T	Qty screws	⊕	⊕	Weight (kg)	*OP max. (bar)
50	165	125	43	402	100	140	ISO 228-G¼	M16	17	4	2	2	9	10
65	185	145	46	435	100	140	ISO 228-G¼	M16	18	4	2	2	11	10
80	200	160	46	495	100	140	ISO 228-G¼	M16	13	8	2	6	13	8
100	220	180	52	568	100	140	ISO 228-G¼	M16	16	8	2	6	17	6
125	250	210	56	627	100	140	ISO 228-G¼	M16	18	8	2	6	21	5
150	285	240	56	728	160	180	ISO 228-G¼	M20	16	8	2	6	33	10
200	340	295	60	863	160	180	ISO 228-G¼	M20	18	8	2	6	42	6
250	395	350	68	1036	200	220	ISO 228-G¼	M20	21	12	4	8	76	6
300	445	400	78	1176	200	220	ISO 228-G¼	M20	21	12	4	8	90	5
350	505	460	78	1369	250	270	ISO 228-G½	M20	18	16	4	12	148	6
400	565	515	102	1502	250	270	ISO 228-G½	M24	24	16	4	12	178	5
450	615	565	114	1652	250	270	ISO 228-G½	M24	28	20	6	14	217	4
500	670	620	127	1770	300	320	ISO 228-G½	M24	28	20	6	14	248	4
600	780	725	154	2063	300	320	ISO 228-G½	M27	32	20	6	14	390	3

*Applicable for supply air pressure of 6 bar in troublefree media. Larger actuators on request.

