

Nominal pressure PN max. 10 bar, flange drilling PN 10

DN	D	K	BL	A	Qty screws	Actuating Flange	Gear SG	Gear/Actuator GS/SA	Weight (kg)
100	220	180	190	130	8 × M16	F07	05	–	16
125	250	210	200	180	8 × M16	F07	05	–	28
150	285	240	210	185	8 × M20	F07	05	–	37
200	340	295	230	210	8 × M20	F07	07	–	41
250	400	350	250	235	12 × M20	F10	10	–	61
300	445	400	270	264	12 × M20	F10	10	–	74
350	505	460	290	295	16 × M20	F12	12	–	104
400	565	515	310	360	16 × M24	F12	12	–	159
500	670	620	350	410	20 × M24	F14	–	100.3/10.1	270
600	780	725	390	510	20 × M27	F16	–	100.3-VZ4.3/07.5	360

Nominal pressure PN max. 16 bar, flange drilling PN 16

DN	D	K	BL	A	Qty screws	Actuating Flange	Gear SG	Gear/Actuator GS/SA	Weight (kg)
100	220	180	190	130	8 × M16	F07	05	–	16
125	250	210	200	180	8 × M16	F07	05	–	28
150	285	240	210	185	8 × M20	F07	05	–	37
200	340	295	230	210	12 × M20	F10	07	–	41
250	400	355	250	235	12 × M24	F10	10	–	61
300	455	410	270	264	12 × M24	F12	12	–	74
350	520	470	290	295	16 × M24	F12	12	–	104
400	580	525	310	360	16 × M27	F14	–	80.3/10.1	159
500	715	650	350	410	20 × M30	F14	–	100.3/10.1	270
600	840	770	390	510	20 × M33	F16	–	125.3-VZ4.3/07.5	360

Large size on request.

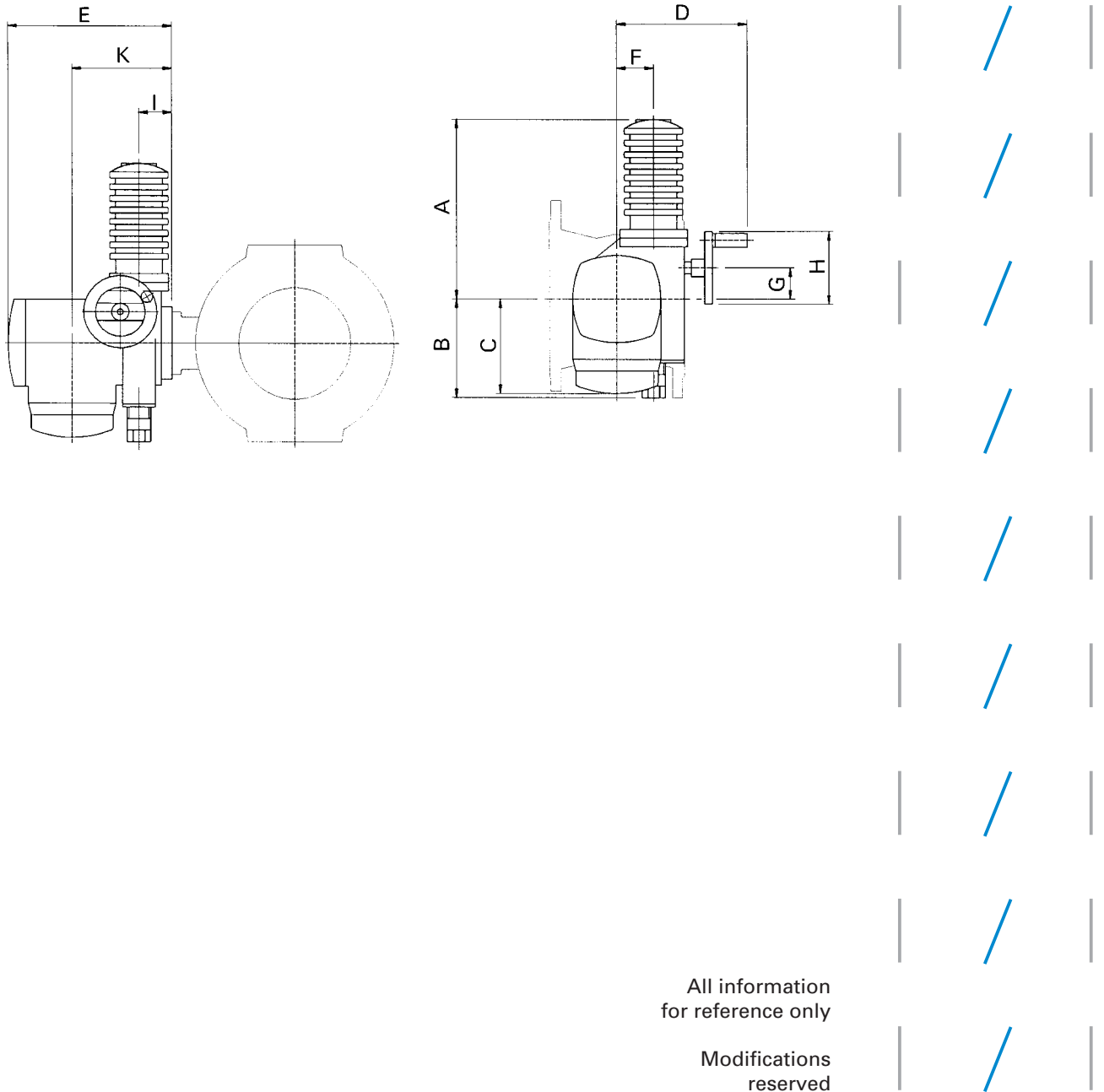

Part-turn Actuator SG 05–SG 12

Actuator	A	B	C	D	E	F	G	H	I	K	Actuating Flange	Weight (kg)
SG 05	300	150	135	150	265	40	45	125	50	170	F07	18
SG 07	300	150	135	155	265	40	45	125	50	170	F07	18
SG 10	310	188	170	160	280	63	54	125	56	170	F10	23
SG 12	310	188	195	170	305	80	54	140	70	195	F12	29

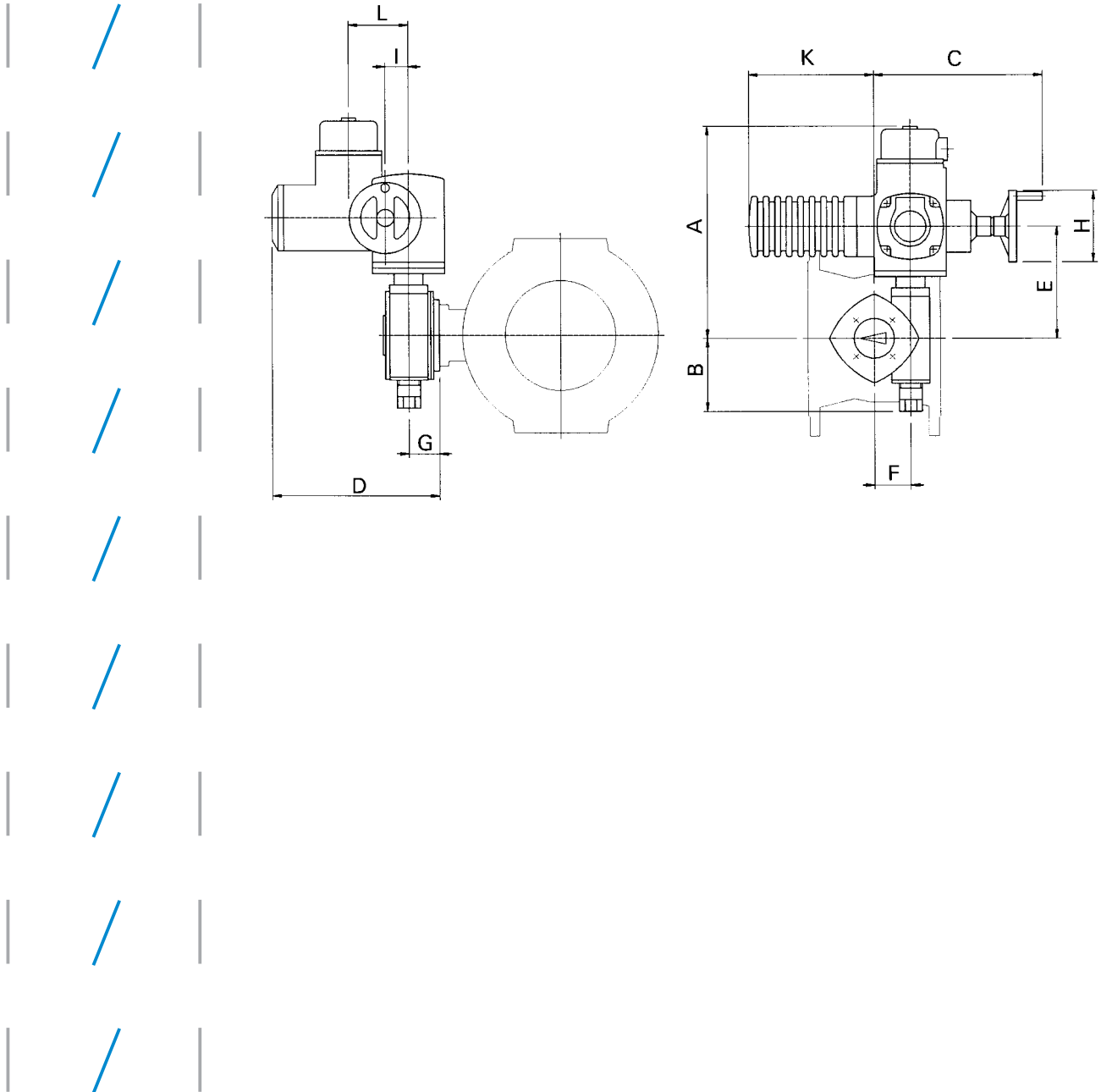

Worm Gear Type GS with multi-turn actuator SA

Gear/Actuator GS/SA	A	B	C	D	E	F	G	H	I	K	L	GS Flange	SA Flange	Weight (kg)
80.3/07.5	408	132	330	284	208	80	47	160	40	185	143	F12	F10	39
80.3/10.1	410	132	336	294	230	80	57	200	50	202	153	F14	F10	43
100.3/10.1	470	182	356	322	270	100	75	200	50	182	153	F14	F10	52
100.3-VZ4.3/07.5	527	182	350	312	327	100	75	160	40	165	143	F16	F10	59
125.3-VZ4.3/07.5	532	187	375	312	332	125	75	160	40	140	143	F16	F10	66